



## Complementary products Beer dispenser "Flex" - stainless steel with wheels

ITEM # \_\_\_\_\_

MODEL # \_\_\_\_\_

NAME # \_\_\_\_\_

SIS # \_\_\_\_\_

AIA # \_\_\_\_\_



725123 (DMSTSSG)

Beer dispenser "Flex 20" +2°C  
s/s with wheels

### Main Features

- System for keeping the beer cool from the keg to the dispensing tap.
- External recyclable packaging designed to allow products to be stacked and to maximise the number of loaded pieces.
- Specially designed refrigerator to cool and store dedicated 20 litres PET plastic kegs, equipped with innovative pressurized system (under pressure of 1,5 bar).
- Stainless steel grid for glasses specially designed to limit splashing.
- Wheels kit included (2 wheels with brakes and 2 without brakes).

### Construction

- Control panel with electronic thermostat.
- Foamed body covered by a curved panel in galvanized steel, with serigraphy in four colors.
- Polypropylene basin for liquid.
- Black polypropylene top with splashback.

### Optional Accessories

- 4 wheels, 2 with brakes, for "draughtmaster" PNC 880190

APPROVAL: \_\_\_\_\_



Experience the Excellence  
[www.electroluxprofessional.com](http://www.electroluxprofessional.com)

Front

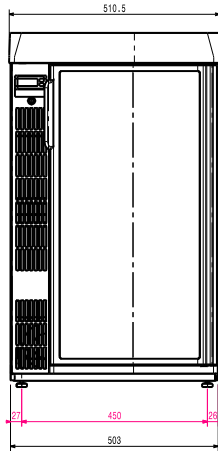

Side

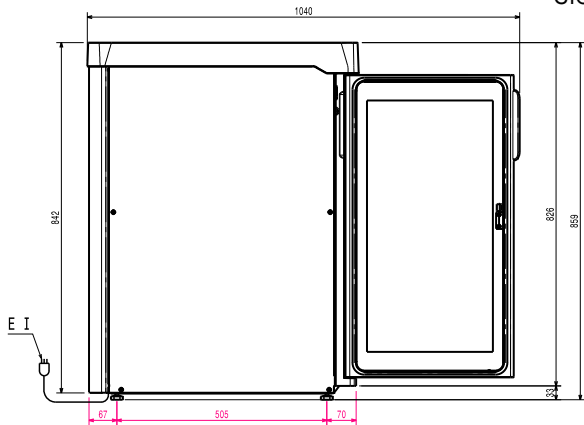

Top

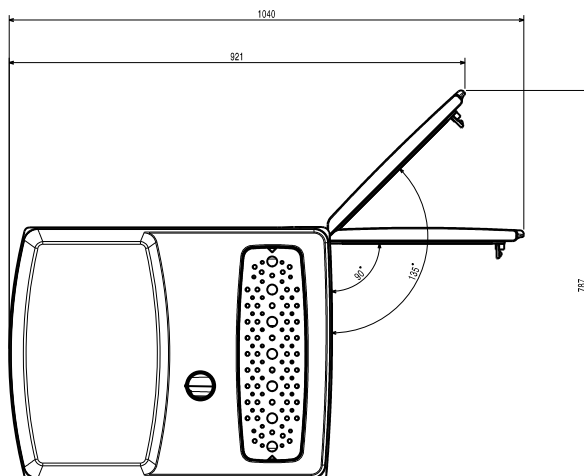

#### Electric

##### Supply voltage:

725123 (DMSTSSG) 220-240 V/1 ph/50 Hz

##### Electrical power max.:

0.34 kW

##### Plug type:

CE-SCHUKO

#### Key Information:

External dimensions, Width: 511 mm

External dimensions, Depth: 652 mm

External dimensions, Height: 916 mm

Net weight: 46 kg

Packaging size

(WxDxH): 520x620x960 mm

Type of external material:

Stainless Steel

Weight Packaging:

53.55 kg

Refrigerant quantity:

35 g. 0

#### Refrigeration Data

Cooling unit:

Built-In

N° defrost in 24 hrs:

4/25'

#### Sustainability

Refrigerant type:

R600a

Refrigeration power:

210 W